

# City of Hamilton, MT

Phase II Zoning Update

Proposed

Residential District Amendments

**1st Draft - September 2024**



## Phase II Zoning Update Overview

This document outlines the first draft of proposed phase II residential zoning amendments for the City of Hamilton. These amendments look to balance the need for increased housing production while ensuring new development fits the character of Hamilton’s varied neighborhoods. To that end, the proposed amendments would allow for increased residential densities in Hamilton and would also place added requirements on building to address the form and scale of new development. One way this would be achieved is through restructuring existing residential zoning districts as outlined below and on page 2.

Existing Zoning District	Proposed Zoning District
Single-Family Residential (RS)	Traditional Neighborhood (R1)
Multi-Family Residential (RM)	Medium Density Residential (R2)
Residential High Density (RH)	High Density Residential (R3)

Phase II of Hamilton’s zoning update began in the fall of 2023 guided by the following four focus areas:

1. Attainable Housing
2. Differentiating Between Mature and Developing Areas
3. Reevaluating Permitted and Conditional Uses
4. Recent State Law Changes

Through a series of neighborhood meetings and zoning update working group meetings these focus areas have been narrowed down to the proposed zoning amendments outlined here. There will be more proposed phase II zoning amendments dealing with commercial zoning, however due to the scope of amendments and based on public interest, this document and September 2024 public meetings are focused on residential zoning.

### An Iterative Process

The proposed zoning amendments outlined in this document are a first draft intended to be reviewed and scrutinized by the Hamilton community. City planning staff continue to wrestle with questions that require the community to weigh in on. What is an appropriate height limit for accessory dwelling units? Should four story apartment buildings be allowed anywhere? How do we allow for incremental increases in housing while preserving community character? The City’s expectation is that through community conversations and feedback the proposed zoning amendments will be refined and improved to better reflect Hamilton’s values and priorities.







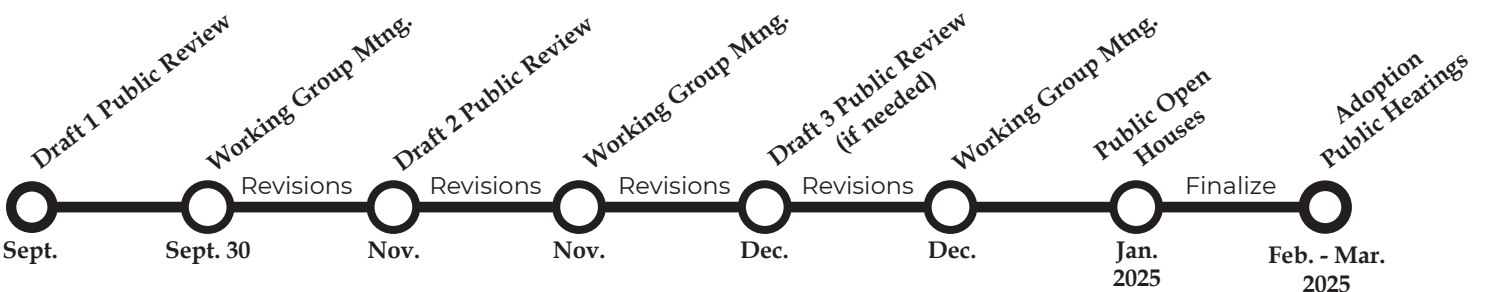

### Why is this needed?

Hamilton’s zoning code has not been substantially updated in 20 years. In that time the Bitterroot Valley has grown, community needs have changed, and state laws have been amended. Additionally, Hamilton’s, and Montana’s, acute housing shortage has become an ever-present concern coupled with residents’ desire to preserve what we love about Hamilton. In response to these factors, and with direction from the City’s Comprehensive Plan, the whole of Hamilton’s zoning code and zoning map are being reviewed for updates. The approach has and will continue to be incremental, with updates occurring in phases.









## Phase II Zoning Update Schedule



## CURRENT ZONING CODE allows for...

	Single fam. Home 	Duplex 	Fourplex 	Sixplex 	Eightplex 	Cottage Court 	Community Residential < 8 people 	Day-Care Homes 
<b>RS</b>	Allowed	Allowed as a Conditional Use	Not Allowed	Not Allowed	Not Allowed	Not Allowed	Allowed as a Conditional Use	Allowed as a Conditional Use
<b>RM</b>	Allowed	Allowed	Allowed	Allowed as a Conditional Use	Allowed as a Conditional Use	Not Allowed	Not Allowed	Not Allowed
<b>RH</b>	Allowed	Allowed	Allowed	Allowed	Allowed	Allowed	Not Allowed	Not Allowed

## PROPOSED 1ST DRAFT ZONING CODE WOULD allow for...

	Single fam. Home 	Duplex 	Fourplex 	Sixplex 	Eightplex 	Cottage Court 	Community Residential < 8 people 	Day-Care Homes 
<b>R1</b>	Allowed	Allowed	Allowed	Not Allowed	Not Allowed	4 Units or Fewer	Allowed	Allowed
<b>R2</b>	Allowed	Allowed	Allowed	Allowed	Not Allowed	6 Units or Fewer	Allowed	Allowed
<b>R3</b>	Allowed	Allowed	Allowed	Allowed	Allowed	Allowed	Allowed	Allowed

# R-1: Traditional Neighborhood District

## Proposed New District, 1st Draft - September 2024

### Intent

The R-1 district is intended to be a walkable residential neighborhood, with blocks, alleys, and within walking distance of retail & services. The R-1 district accommodates a variety of low-intensity housing options including detached single-family homes, multi-family dwellings up to four units, and accessory dwelling units. The R-1 district is intended for areas of infill on Hamilton's west side as well as developing areas intended to replicate patterns of traditional neighborhood development.

### Uses

#### Permitted Uses

- |   |                      |
|---|----------------------|
| Single-family dwellings                         | Short-term rentals   |
| Multi-family dwellings, 2-4 units               | Accessory buildings  |
| Cottage courts (4 units or fewer)*              | Manufactured housing |
| Accessory dwelling units*                       | Day-care homes*      |
| Community residential facilities ≤ 8 residents* | Home occupations     |

#### Conditional Uses

- Churches
- Community Centers

\*See page 20 for definition

### Lot Standards

#### Minimum Lot Area **A**

- |                |               |
|----------------|---------------|
| 1-2 dwellings  | 4,200 SF      |
| 3-4 dwellings  | 2,000 SF/unit |
| All other uses | 4,200 SF      |

#### Min. Lot Width **B**

- |                |     |
|----------------|-----|
| 1-2 dwellings  | 30' |
| 3-4 dwellings  | 50' |
| All other uses | 30' |

#### Max. Lot Coverage

40%



# Building Standards

## Minimum Building Setbacks

### Front Yard C

3 & 4 unit bldgs.	10'
Front facing garages	10' behind front of main bldg.
All other bldgs.	20'

### Side yard D

1 - 1.5 story bldgs.	5'
2 - 2.5 story bldgs.	
Duplexes	5'
All other bldgs.	10'
Corner lots	10' along non-frontage street

### Rear yard E

Main bldg.	20'
Accessory bldgs.	5'

### Encroachments F

Porches, bay windows, stairs, roof eaves and the like may encroach into setbacks, as outlined below. Encroachments shall not encroach closer than 2' to any property line.

Front	5'
Side	3'
Rear	10'

## Maximum Building Height G

### Main Building 2.5 stories / 30'

### Accessory Building

Accessory dwelling unit	No higher than main dwelling
All other accessory bldgs.	2 stories / 20'

### Chimney's & antennas 5' above highest roofline

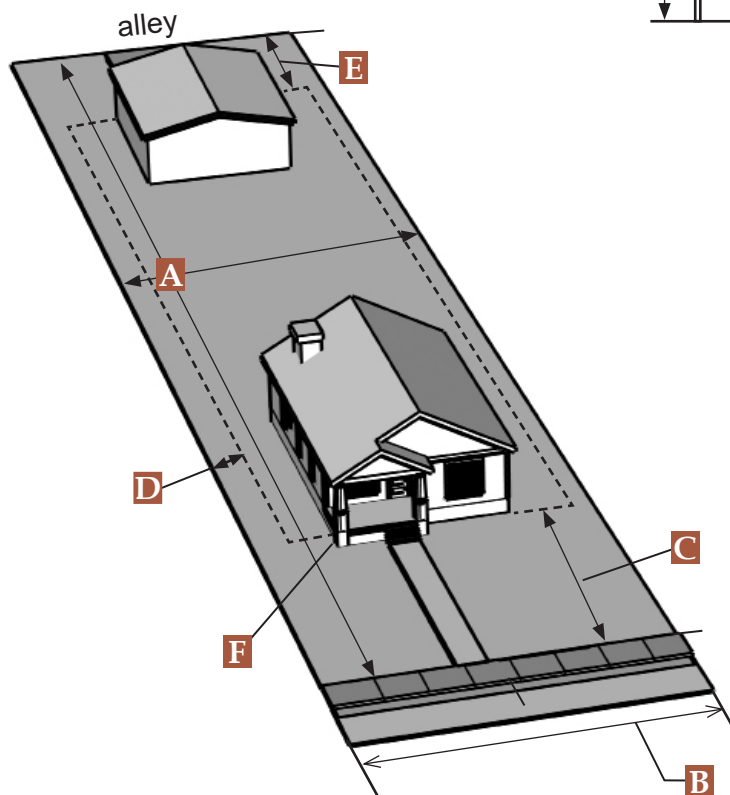
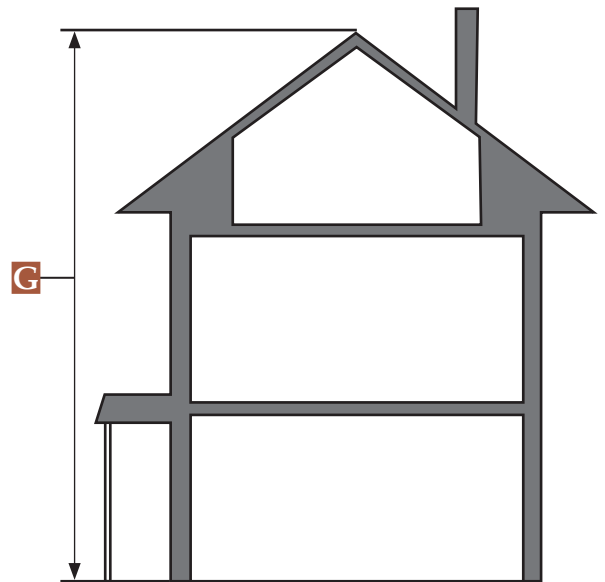

# R-1: Traditional Neighborhood District

## Proposed New District, 1st Draft - September 2024



# RS: Single-Family Residential District

## Current Zoning District

### Intent

The RS district establishes zoning for primarily single-family dwellings on urban lots.

### Uses

#### Permitted Uses

Single-family dwellings	Short-term rentals
Accessory dwelling units	Home occupations
Accessory buildings	Incidental uses

#### Conditional Uses

Multi-family dwellings, 2 units	Group day care homes
Foster care	Libraries
Community residential facilities $\leq$ 12 residents	Parks & open space
Day care centers & preschools	Playgrounds & recreation
Day care homes	Schools

### Lot Standards

#### Minimum Lot Area

All uses 4,200 SF

#### Minimum Lot Width

All uses 30'

#### Max. Lot Coverage

N/A

### Building Standards

#### Minimum Building Setbacks

Front Yard	15'
Side yard	
All bldgs. & uses	5'
Corner lots	10' along non-frontage street

#### Rear yard

Main bldg.	20'
Accessory bldg.	5'
Garages opening to alley	10'

#### Maximum Building Height

Main Building	2.5 stories / 35'
Accessory Building	2 stories / 25'
Churches (CUP)	45'

# R-2: Medium Density Residential District

## Proposed New District, 1st Draft - September 2024

### Intent

The R-2 district is intended to be a walkable residential neighborhood accommodating a variety of low to moderate-intensity housing options including detached single-family homes, duplexes up to six-plexes, and accessory dwelling units. The R-2 is intended for areas that have developed more recently as well as newly developing areas.

### Uses

#### Permitted Uses

Single-family dwellings	Short-term rentals
Multi-family dwellings, 2-6 units	Accessory buildings
Cottage courts (6 units or fewer)*	Manufactured housing
Townhouses	Day-care homes*
Accessory dwelling units*	Home occupations
Community residential facilities ≤ 8 residents*	

#### Conditional Uses

- Churches
- Community Centers

\*See page 20 for definition

### Lot Standards

#### Minimum Lot Area A

1-2 dwellings	4,000 SF
3-4 dwellings	6,000 SF
5-6 dwellings	8,000 SF
Townhouses	2,000 SF
All other uses	4,000 SF

#### Min. Lot Width B

1-2 dwellings	30'
3-4 dwellings	50'
5-6 dwellings	60'
Townhouses	20'
All other uses	30'

#### Max. Lot Coverage

50%

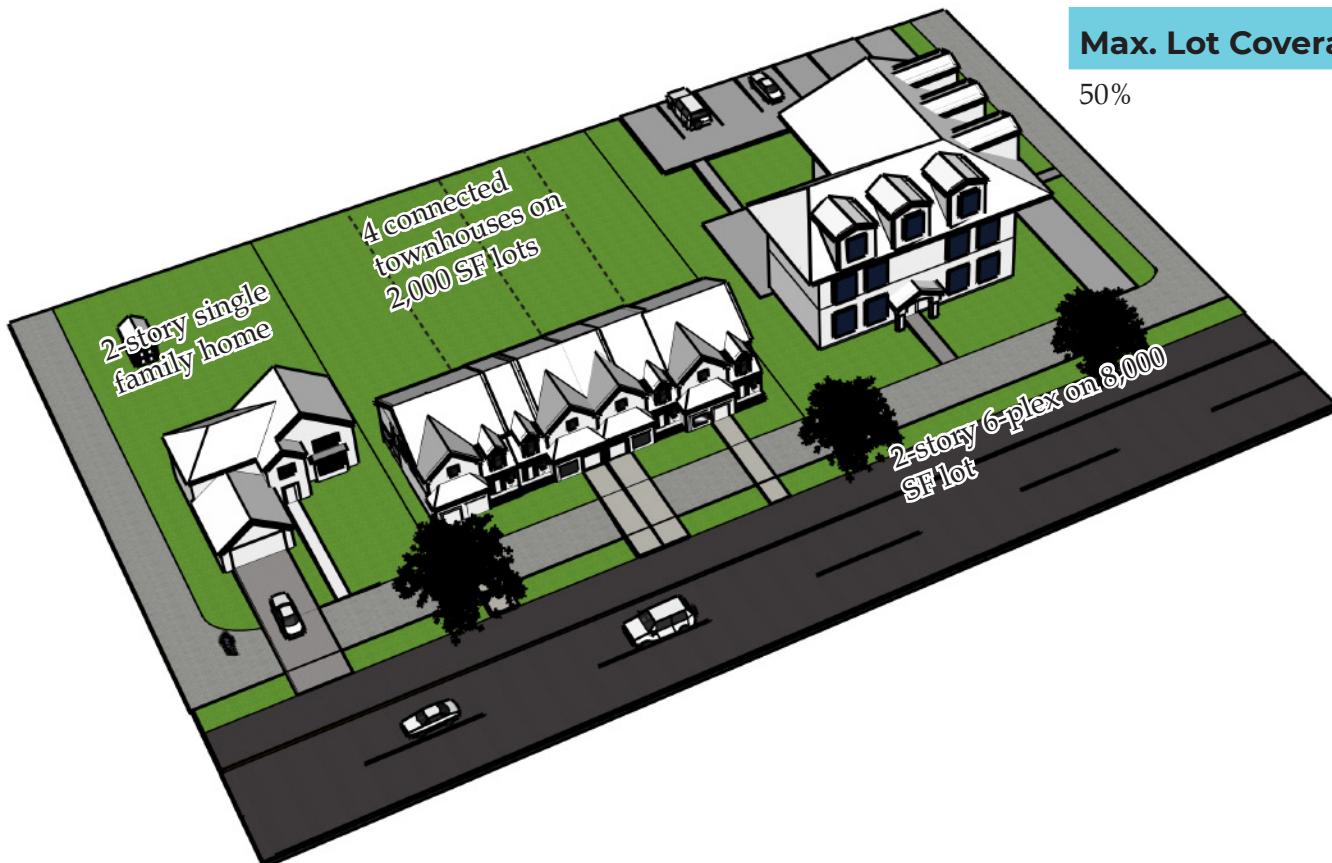



# Building Standards

## Minimum Building Setbacks

### Front Yard C

3 & 4 unit bldgs.	10'
Townhouses	10'
All other bldgs.	15'

### Side yard D

Townhouse interior walls	0'
All other bldgs.	5'
Corner lots	10' along non-frontage street

### Rear yard E

Main bldg.	20'
Accessory bldg.	5'

### Encroachments F

Porches, bay windows, stairs, roof eaves and the like may encroach into setbacks, as outlined below. Encroachments shall not encroach closer than 2' to any property line.

Front	5'
Side	3'
Rear	10'

## Maximum Building Height G

### Main Building

Townhouse	2 stories / 25'
All other bldgs.	2.5 stories / 30'

### Accessory Building

Accessory dwelling unit	No higher than main dwelling
All other accessory bldgs.	2 stories / 25'

**Chimney's & antennas** 5' above highest roofline

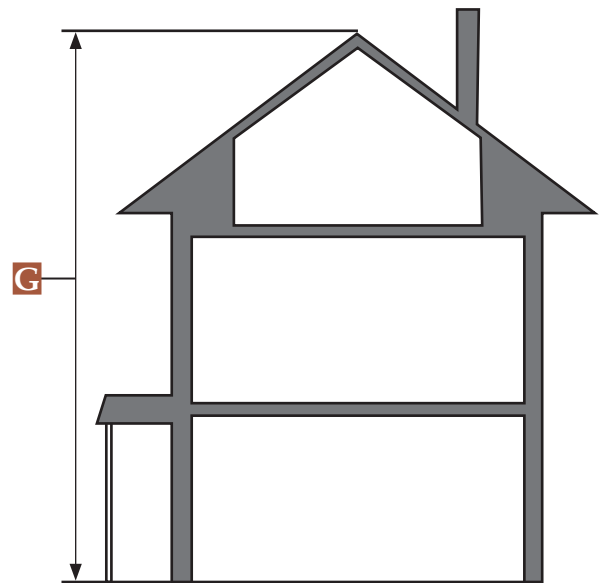
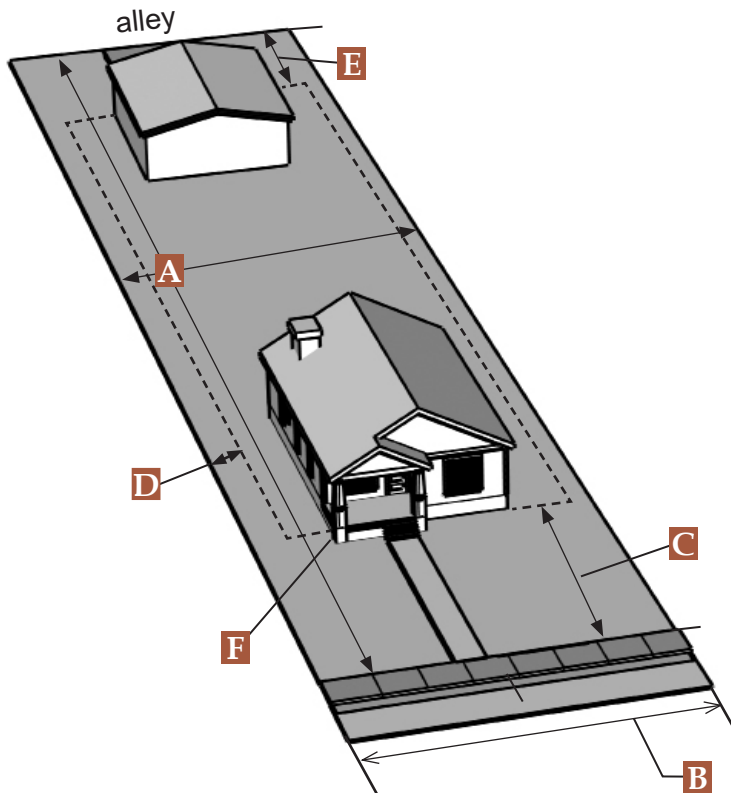

# R-2: Medium Density Residential District

Proposed New District, 1st Draft - September 2024



# RM: Multiple-Family Residential District

## Current Zoning District

### Intent

The RM district establishes zoning for one to four family dwelling units.

### Uses

#### Permitted Uses

Single-family dwellings	Short-term rentals
Townhouses	Home occupations
Multi-family dwellings, 2-4 units	Incidental uses
Accessory dwelling units	Accessory buildings

#### Conditional Uses

Multi-family dwellings, 5-8 units	Parks & open space
Boarding and lodging houses	Playgrounds & recreation
Personal & food services in multi-family	Schools
Community centers	Churches > 45'
Libraries	Churches

### Lot Standards

#### Minimum Lot Area

Single home	4,200 SF
Townhouses	4,200 SF
2+ dwellings	2,500 SF/unit
All other uses	8,000 SF

#### Min. Lot Width

Single home	30'
Townhouses	30'
2 dwellings	50'
3+ dwellings	60'
All other uses	60'

#### Max. Lot Coverage

N/A

### Building Standards

#### Minimum Building Setbacks

Front Yard	15'
Side yard	
Townhouse interior walls	0'
All other bldgs.	5'
Corner lots	10' along non-frontage street

#### Rear yard

Main bldg.	20'
Accessory bldg.	5'
Garages opening to alley	10'

#### Maximum Building Height

Main Building	3 stories / 45'
Accessory Building	2 stories / 25'

# R-3: High Density Residential District

## Proposed New District, 1st Draft - September 2024

### Intent

The R-3 district is intended to provide for higher density housing through a variety of building types including apartments, cottage courts, townhouses, and condominiums.

### Minimum Density

The minimum density in the R-3 district shall be 14 dwelling units per acre.

### Uses

#### Permitted Uses

- |   |                        |
|---|------------------------|
| Single-family dwellings                         | Short-term rentals     |
| Multi-family dwellings, 2-6                     | Accessory buildings    |
| Apartments & apartment bldgs.*                  | Single room occupancy* |
| Cottage courts*                                 | Manufactured housing   |
| Townhouses                                      | Day-care homes*        |
| Accessory dwelling units*                       | Home occupations       |
| Community residential facilities ≤ 8 residents* |                        |

#### Conditional Uses

- Churches
- Day care centers\*
- Community Centers

\*See page 20 for definition

### Lot Standards

#### Minimum Lot Area **A**

None

#### Min. Lot Width **B**

- |                |     |
|----------------|-----|
| 1-2 dwellings  | 30' |
| 3-6 dwellings  | 50' |
| Townhouses     | 16' |
| All other uses | 60' |

#### Max. Lot Coverage

70%

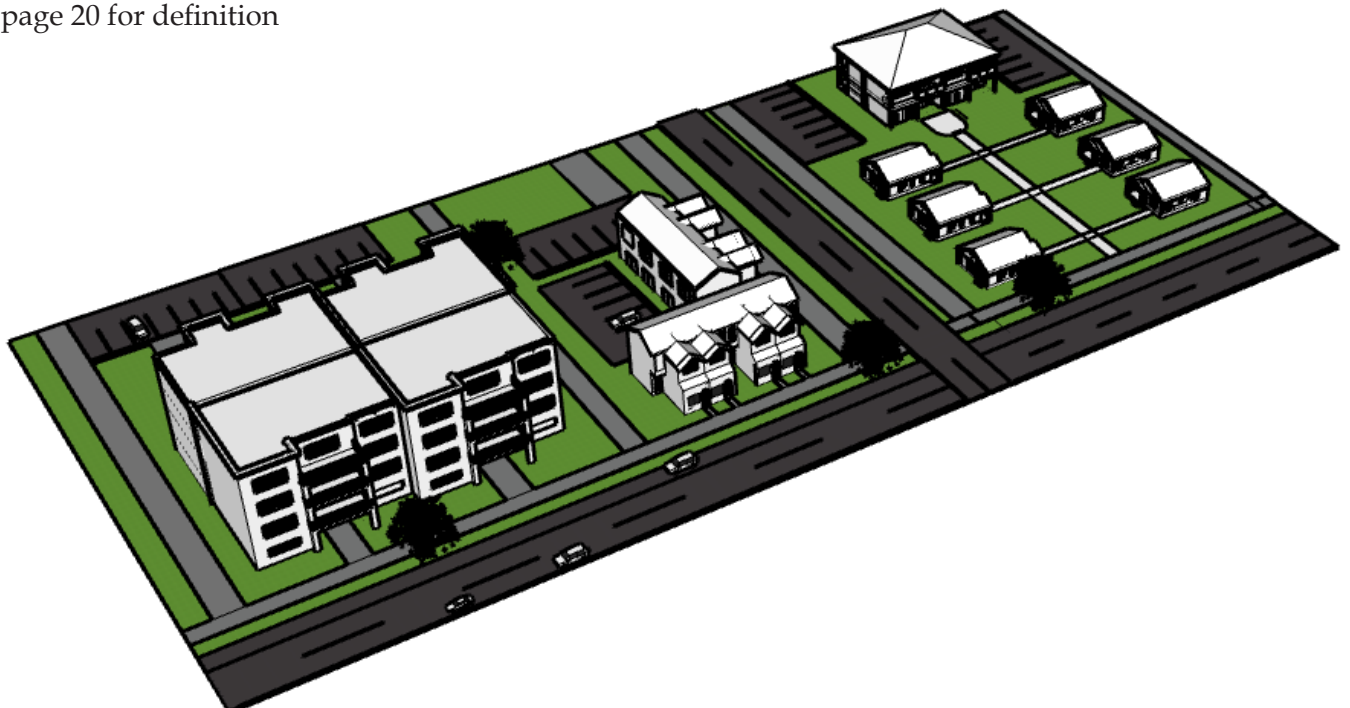

# Building Standards <sup>1</sup>

## Minimum Building Setbacks

### Front Yard C

Townhouses	5'
All other bldgs.	15'

### Side yard D

Townhouse interior walls	0'
All other bldgs.	5'
Corner lots	10' along non-frontage street

### Rear yard E

Main bldg.	15'
Accessory bldg.	5'

### Encroachments F

Porches, bay windows, stairs, roof eaves and the like may encroach into setbacks, as outlined below. Encroachments shall not encroach closer than 2' to any property line.

Front	5'
Side	3'
Rear	10'

<sup>1</sup> Residential buildings with 7 or more units facing public areas are subject to the building and site development standards.

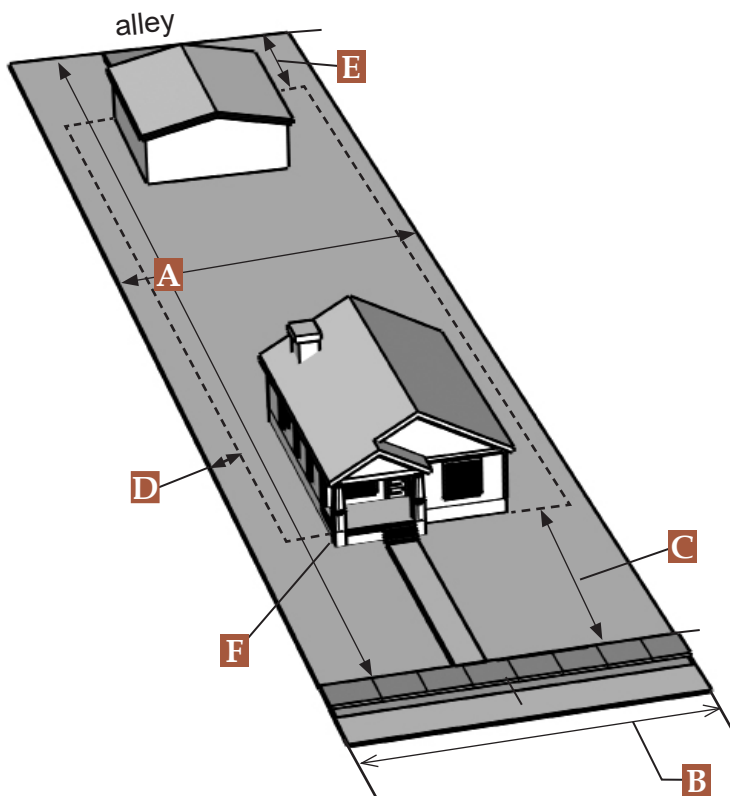

## Maximum Building Height G

### Main Building

Townhouse	2 stories / 25'
All other bldgs.	4 stories / 60'

### Accessory Building

Accessory dwelling unit	No higher than main dwelling
Other accessory bldgs.	2 stories / 25'

Chimney's & antennas 5' above highest roofline

## Maximum Building Footprint

Main building(s)	12,000 SF per bldg.
Accessory building(s)	2,000 SF per bldg.

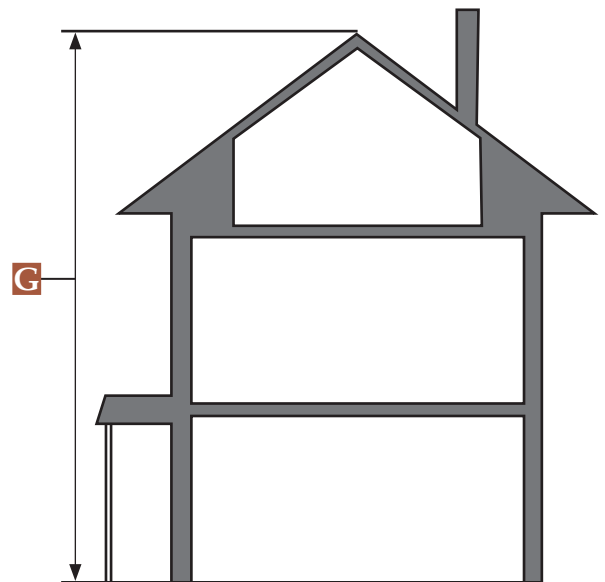

# R-3: High Density Residential District

## Proposed New District, 1st Draft - September 2024



# RH: Residential High Density District

## Current Zoning District

### Intent

The RH district establishes zoning for multiple-family dwelling units.

### Uses

#### Permitted Uses

Single-family dwellings	Short-term rentals
Multi-family dwellings	Accessory buildings
Townhouses	Home occupations*
Accessory dwelling units	Incidental uses

#### Conditional Uses

Boarding & lodging houses
Personal & food services in multi-family

### Lot Standards

#### Minimum Lot Area

1-2 dwellings	4,200 SF
3-4 dwellings	2,000 SF/unit
5-8 dwellings	1,200 SF/unit
8+ dwellings	10,000 SF + 1,400 SF/each unit over 8
Townhouses	1,600 SF

#### Min. Lot Width

1-2 dwellings	30'
Townhouses	20'
All other uses	50'

#### Max. Lot Coverage

N/A

### Building Standards

#### Minimum Building Setbacks

Front Yard	15'
Side yard	
Townhouse interior walls	0'
All other bldgs.	5'
Corner lots	10' along non-frontage street

#### Rear yard

Main bldg.	20'
Accessory bldg.	5'
Garages opening to alley	10'

#### Maximum Building Height

Main Building	3 stories / 45'
Accessory Building	2 stories / 25'

# Current Zoning

- RS | Single-Family Residential
- RM | Multiple-Family Residential
- RH | Residential High Density
- MHP | Mobile Home Park Residential
- B | Transitional Neighborhood Business
- B1 | Local Business
- B2 | Highway Related Business
- CBD | Central Business
- PS | Professional Services Business
- CM | Commercial or Manufacturing
- PI | Public and Institutional
- PUD | Planned Unit Development

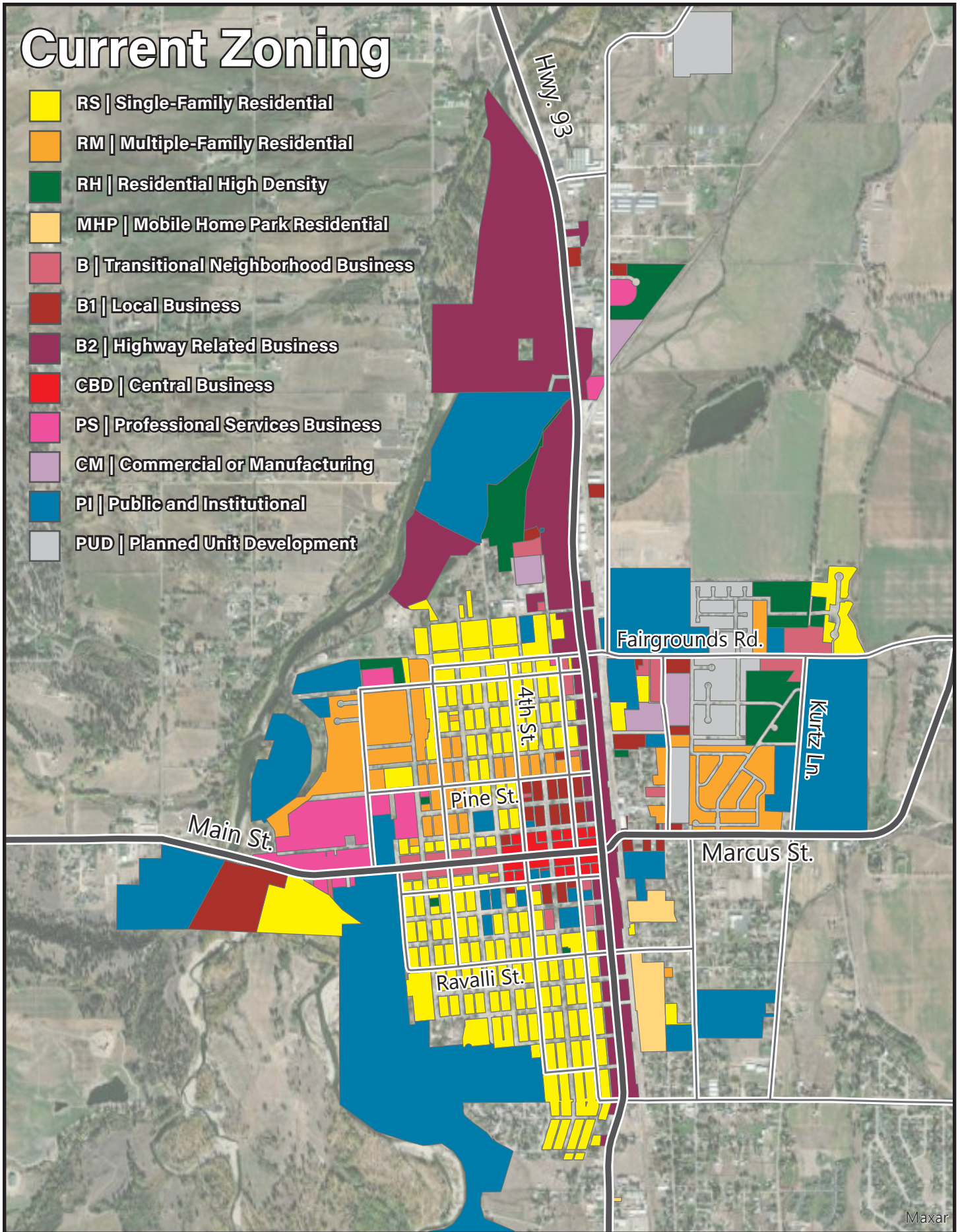

Maxar



# Concept Zoning Map Update

1st DRAFT - September 2024

-  R1 | Traditional Neighborhood
-  R2 | Medium Density Residential
-  R3 | High Density Residential

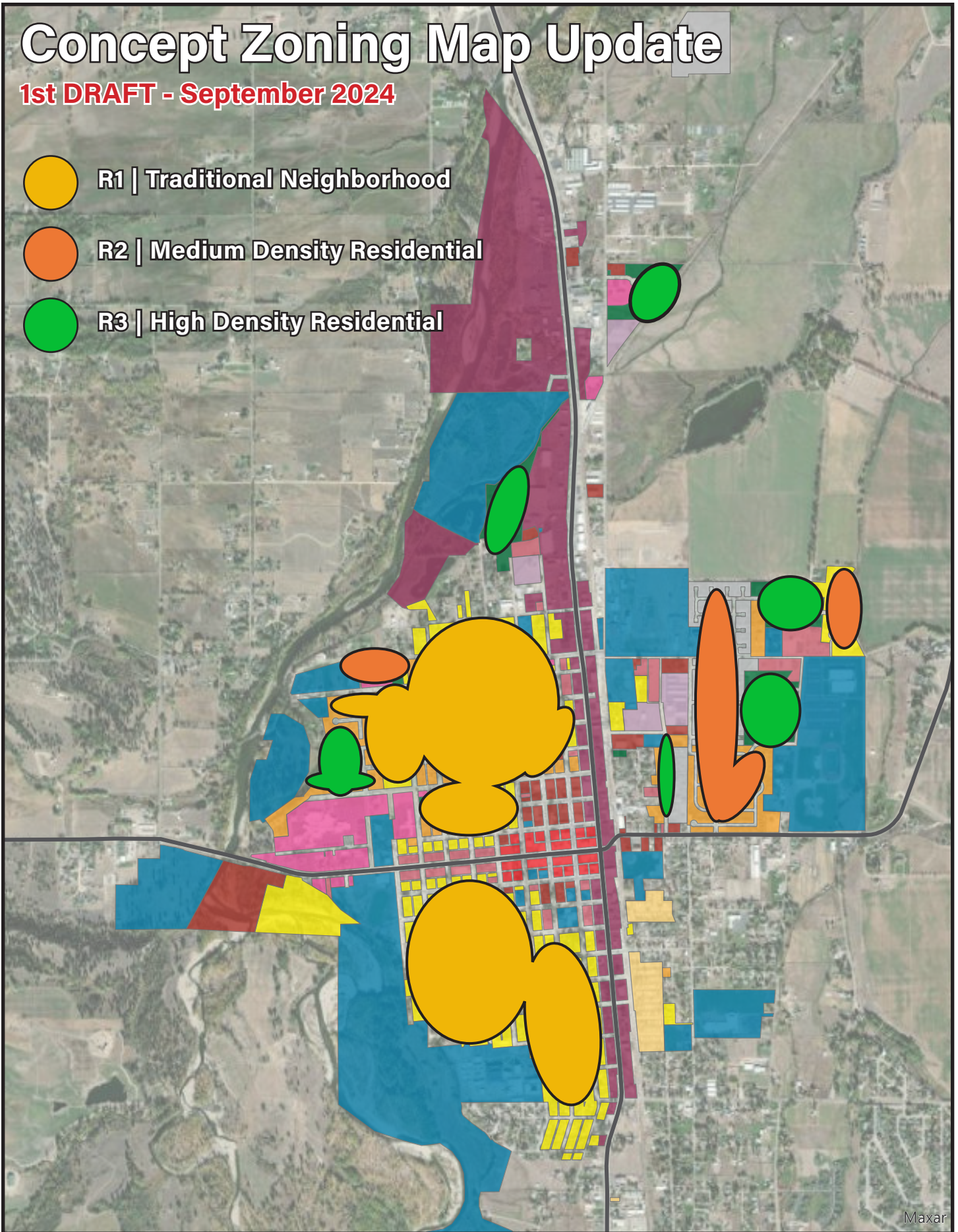

Maxar

# Building & Site Development Standards

## Proposed New Standards, 1st Draft - September 2024

### Purpose

The purpose of the building and site development standards is to enhance the character, quality, health, and safety of new and existing neighborhoods by requiring development to meet certain standards for building facades facing public spaces.

### Applicability

Building and site development standards apply to building facades of residential buildings with seven or more units and mixed-used residential-commercial buildings that are adjacent to:

1. Public or private streets, OR
2. Public parks or non-motorized paths.

### Standards

#### Minimum Facade Transparency

Building facades shall meet the minimum transparency requirements outlined below. The percentage of transparency per story shall be calculated within the area between finished floor and finished ceiling

1. First story: 30%
2. Upper stories: 20%

#### Primary Entrance

Where a building is adjacent to a public street, its primary entrance must be located along and directly face the street. Additional building entrances are permitted.

#### Buildings Adjacent to the R-1 & R-2 Districts

Buildings over two stories tall shall meet the following requirement for each façade adjacent to property zoned R-1 or R-2.

1. Each story over two shall be setback an additional 10-feet per story.

# Townhouse Development Standards

## Proposed New Standards, 1st Draft - September 2024

### Intent

The intent of this section is to allow for a range of home ownership options while also upholding public health, safety, and general welfare for townhouse developments. It is further the intent of this section to facilitate townhouse developments exempt from subdivision review under state law within Hamilton City limits where city infrastructure exists. It is not the intent of this section to facilitate complicated development proposals outside of city limits requiring annexation and extension on city infrastructure. Those developments should be pursued through the subdivision process.

### Applicability

Townhouse developments are a permitted use in the R-2, R-3, and B zoning districts. Townhouse developments that convert spaces in buildings from rental to owner occupancy, that do not include the division of land, do not need to conform to this section.

### Standards

1. Buildings shall not contain more than four attached townhouse units.
2. All detached townhouse buildings shall be separated by a minimum distance of 10-feet
3. Parking
  - a. Access to parking spaces and garages must be from the alley for all townhouses that abut an alley.
  - b. For townhouses without alley access, driveways, parking and other vehicular use areas may not be located between the covered building entrance and the street.
  - c. Garages and carports that abut a street must be set back at least 25 feet from all townhouse parcel lines on public road frontages, or from the back of curb or sidewalk on private roads.
  - d. There must be a minimum of 35 feet distance between single or paired driveways, unless otherwise approved by the city Director of Public Works.
5. Each townhouse lot shall have legal and physical access.
6. Blocks
  - a. Blocks and streets shall be designed to create a grid pattern to the extent possible.
  - b. Blocks and streets shall be designed to maximize connectivity to adjoining developed lands or connectivity potential to adjoining undeveloped lands.
  - c. Block length shall not exceed 600 feet.
4. Each townhouse must have a separate ground-floor entrance that is clearly defined and highly visible on the building façade that faces a street or a right-of-way other than an alley.
5. Orientation
  - a. Townhouse facades must be oriented to public streets, private roads within a public access easement, or courtyards.
  - b. Within individual townhouse developments fronts of townhouses may not face backs of other townhouses.

# Nonconformities

## Proposed Updated Regulations, 1st Draft - September 2024

### What Are Nonconformities?

In zoning, nonconforming, (aka grandfathered) means a use or building which was allowed when it was built but no longer meets current zoning requirements. They are allowed to legally continue but cannot expand, be moved, or replaced. A local example is Hamilton's west side, where many homes and businesses pre-date current zoning and are considered nonconforming with respect to setbacks, use, off-street parking, or the presence of a particular building type (e.g. mobile homes).

### How Are Nonconformities Currently Treated in Zoning?

Hamilton's current zoning takes the stance that all non-conformities are created equal, and they should and will eventually go away. In reality this does not happen, and in many cases it can prevent desired incremental redevelopment and property improvements. Further the uniqueness of Hamilton's downtown and west side neighborhoods is a community asset that many residents wish to preserve rather than require conformity with new development standards. Yet if any of these properties were to expand, redevelop, or be destroyed, they would have to come into compliance with Hamilton zoning, which would result in a development pattern more akin to areas developed in the last 30-years.

### What is Being Proposed for Nonconformities?

The proposed zoning amendments would update Hamilton's nonconforming use regulations (chapter 17.32 of the Hamilton Municipal Code) to distinguish between "benign nonconformities" which do not pose a risk to public health, safety, or general welfare and nonconformities which do pose a risk to public health, safety, or general welfare and should eventually go away. Under the proposed amendments the City's zoning administrator would be able to administratively designate "benign nonconformities" and, subject to compliance with City building codes, permit them to:

1. Expand up to 10% of the floor area of the original structure,
2. Be altered, and
3. Be replaced if they are destroyed or removed.

This would remove the requirement for "benign nonconformities" to apply for a variance and go before the City's Zoning Board of Adjustment at a public hearing. However, the zoning administrator's decision in designating benign nonconformities could still be appealed to the Zoning Board of Adjustment.

### Example Application

A half-acre lot currently zoned single-family residential with eight mobile homes pre-dating zoning would be considered nonconforming with respect to use. The eight mobile homes can continue to be used but if one were destroyed by a falling tree it could not be replaced.

Recognizing mobile homes as an important piece of Hamilton's supply of naturally occurring affordable housing, the proposed amendments to the City's nonconforming regulations would allow the zoning administrator to determine whether replacement of the mobile home would pose any risk to public health, safety, or general welfare. If it does not, then that mobile home could be replaced so long as the total number of mobile homes on the lot does not exceed eight.

# Definitions

<b>Accessory Dwelling Unit</b>	A separate dwelling unit within or attached to a single-family dwelling, a separate dwelling unit that occupies an accessory building located on the same lot as a single-family dwelling, or a detached dwelling unit located on the same lot as a single-family dwelling. Accessory dwelling units shall be permanently located on the ground.
<b>Apartment</b>	A habitable room or suite of two or more habitable rooms, meeting the requirements of the city's adopted International Building Code, located in an apartment building or used for residential purposes in non-residential buildings
<b>Apartment building</b>	A building other than a hotel, motel, townhouse, or rowhouse containing seven or more dwelling units
<b>Community residential facility</b>	A community group home for developmentally, mentally, or severely disabled persons that does not provide skilled or intermediate nursing care; a youth foster home, a kinship foster home, a youth shelter care facility, a transitional living program, or youth group home as defined in MCA 52-2-602; a halfway house operated in accordance with regulations of the department of public health and human services for the rehabilitation of alcoholics or drug dependent persons; a licensed adult foster family care home; or an assisted living facility licensed under MCA 50-5-227.
<b>Cottage court</b>	A development containing a cluster (or clusters) of dwellings on the same lot located around common open space.
<b>Day care home</b>	A private residence or other structure in which day care is provided to 3 to 15 children on a regular basis.
<b>Day care center</b>	An out-of-home place in which day care is provided to 16 or more children on a regular or irregular basis.
<b>Single room occupancy</b>	Attached multifamily residential building with independent sleeping units and shared amenities including cooking facilities, bathrooms, or both; and which are intended for permanent or semi-permanent housing occupancy. They include dormitories and similar housing not associated with a school or institution. Single-room occupancy housing does not include detached units or detached amenity spaces.
<b>Story</b>	The portion of a building included between the surface of any floor and the surface of the next floor above, or if there is no floor above, the space between the surface of any floor and the ceiling above. A basement is not considered a story.
<b>Story, half</b>	The portion of a building between the top floor and a sloping roof, with at least two opposite exterior walls meeting the sloping roof not over three feet above such floor level.